



**Don't Settle for less.
Choose the best.**

Home of SteadyMax - The Most Rigid Pole in The World



STEADYMAX
FLORIDA POLE

Designed to withstand
195 MPH winds!

**Don't Settle for a repurposed light pole.
Choose the engineered solution.**

StrongPoles.com / 844-669-3537



STEADYMAX
FLORIDA POLE

Designed to withstand
190 MPH winds!



STRONGPOLES
SECURITY MOUNTING SOLUTIONS
StrongPoles.com / 844-669-3537

THE ONLY CAMERA POLE FOR EXTREME WINDS

STEADYMAX^{FL}

Strong Poles has designed a new pole to pass Florida Building Code 2017 Specifications for a 190 MPH Wind Speed.



This 12' SteadyMax Pole is the strongest, most rigid pole we have ever made. This incredible SteadyMax Pole can carry a full load of cameras, cabinets, sensors and antennas, yet still maintains our proprietary 3% movement under 190 mph winds.

These engineered camera poles also have a Factory-Installed Vibration Suppression System (Read More) that consists of two different frequency dampeners that quell high and low frequency vibrations and oscillations that may occur during the life of the pole.

The result is the Steadiest, most rigid pole we have ever built, yet is very lightweight (our 12' pole weighs only 65 lbs.). This is an amazing Engineering feat to make a pole this steady, yet this lightweight.

- The 12' SteadyMax Florida Camera Pole is a 6" diameter, non-tapered, heavy wall (.188 thick), aluminum round pole made out of 6063-T6 Aluminum and can be ordered in our usual White or Black (Dark Bronze) Powder Coat finishes.

Steady Max Wind Load Calculations

 Model	EPA Wind Velocity (mph)				 the most rigid poles in the world
	90 mph	100 mph	120 mph	150 mph	
SP-SM12FL	17.4	13.5	8.89	5.76	
SP-SM16	14.5	11	6.8	3.5	
SP-SM20	14.2	10.5	5.7	2.8	
SP-SM25	12.6	9.1	4.3	1.5	

THE TABLE ABOVE SHOWS THE EFFECTIVE PROJECTED AREA (EPA) WIND VELOCITY RATINGS FOR DIFFERENT STRONGPOLES MODELS AT VARIOUS WIND SPEEDS. THE VALUES REPRESENT THE MAXIMUM WIND SPEED (IN MPH) THAT EACH MODEL, CAN WITHSTAND, WHILE MAINTAINING OUR MAXIMUM AVAILABLE MOVEMENT CONSIDERING A GUST FACTOR OF 1.3. THIS GUST FACTOR ACCOUNTS FOR SUDDEN INCREASES IN WIND SPEED, ENSURING THE POLES CAN HANDLE SHORT BURSTS OF HIGHER WIND SPEEDS WITHOUT COMPROMISING STABILITY.



STEADYMAX^{FL}

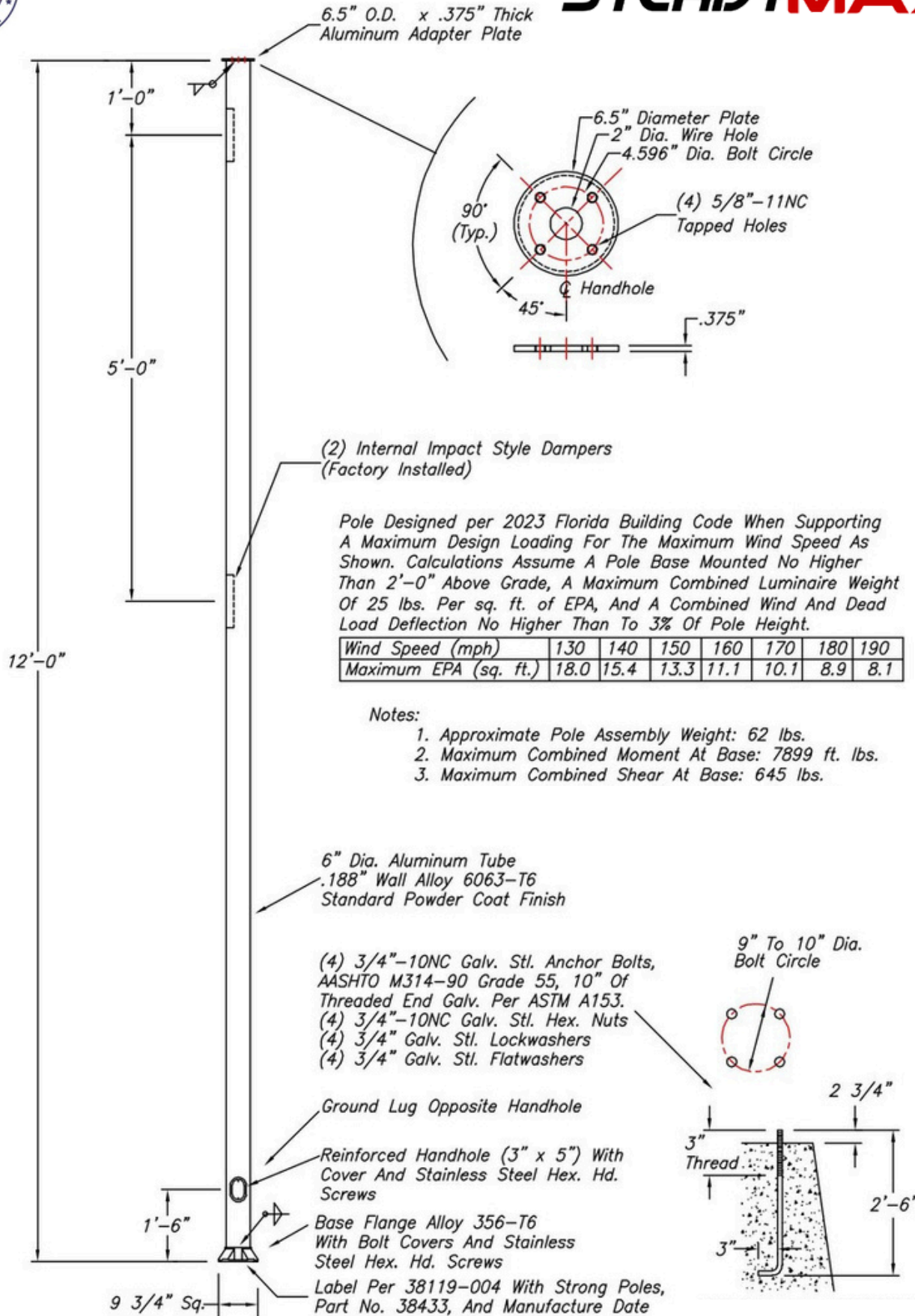



SteadyMax 12/16 Anchor Basket Assembly

Strong Poles' pre-engineered Anchor Baskets makes installations much faster, and alignment much easier. Simply push the Anchor Basket down into the wet concrete until the template is flush with the top of the concrete, and be sure that the conduit rises well above the hole in the template. Then before the concrete is cured, Remove the template and make sure foundation is level and smooth to mount the pole.

Strong Poles pre-sets each lug to the perfect height for mounting (so the lugs do not sit up too high to get the base cover in place correctly.)

Each Anchor Basket has been preset to have a projection of the bolts above the concrete at the perfect height to allow the finish caps to fit onto the pole base.

NOTE: Please do not use a twin nut leveling system, (commonly found on light poles). Our Poles must be fastened directly to the concrete. Then before the concrete is cured, Remove the template and make sure foundation is level and smooth to mount the pole

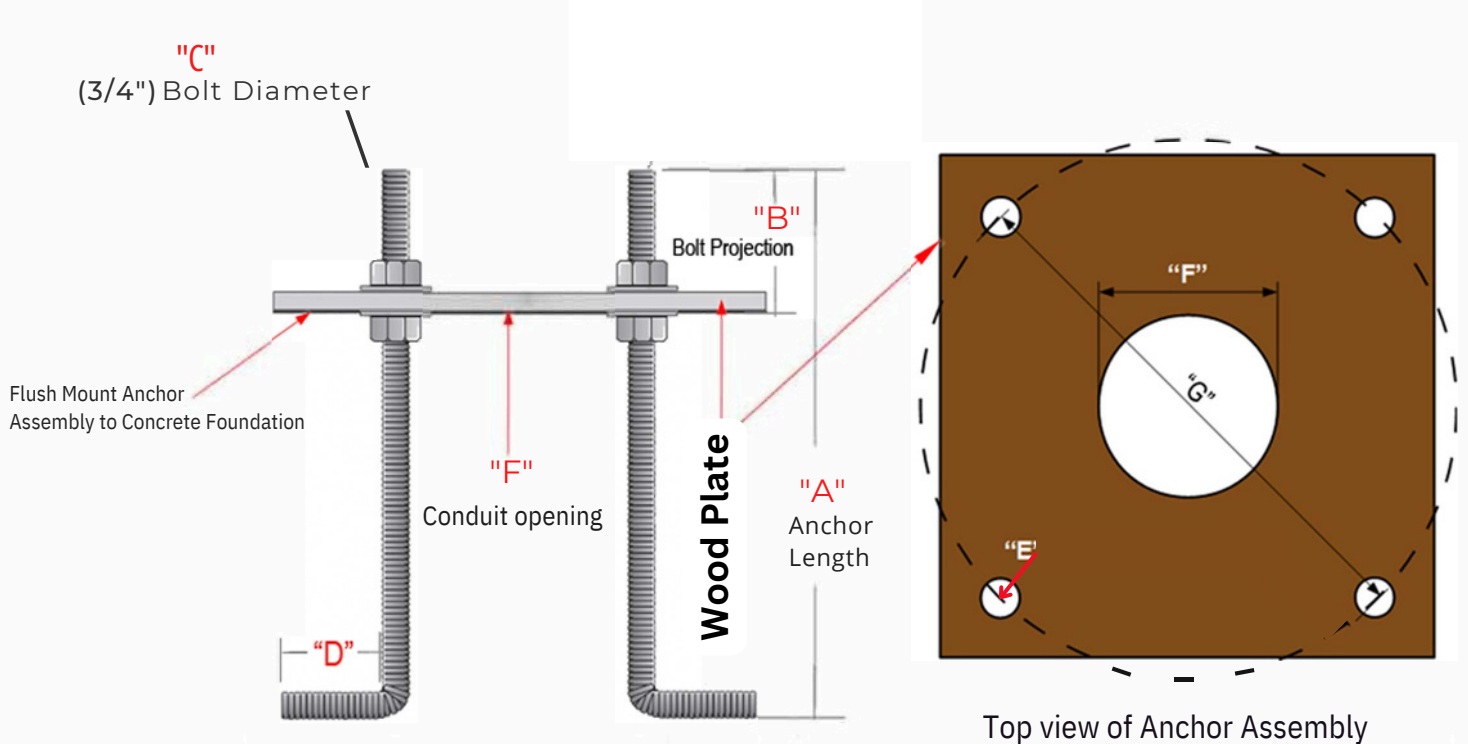

POLE SIZE	STRONGFORM	ANCHOR ASSEMBLY PART	"A" ANCHOR LENGTH	"B" BOLT PROJECTION	"C" BOLT DIAMETER	"D" ANCHOR LENGTH	"E" HOLE DIAMETER	"F" CONDUIT SIZE	"G" BCD
SteadyMax SP-SM12	StrongForm-18-5	Included	30"	2-1/2"	3/4"-10	3"	13/16"	Max OD 4"	9.5"
SteadyMax SP-SM16	StrongForm-18-5	Included	30"	2-1/2"	3/4"-10	3"	13/16"	Max OD 4"	9.5"

PART 1 GENERAL

1.01 SECTION INCLUDES

- A. Accessories.

1.02 RELATED REQUIREMENTS

- A. Section 033000 - Cast-in-Place Concrete: Materials and installation requirements for concrete bases for camera poles.
- B. Section 078400 - Firestopping.
- C. Section 260526 - Grounding and Bonding for Electrical Systems.
- D. Section 260529 - Hangers and Supports for Electrical Systems.
- E. Section 260553 - Identification for Electrical Systems: Identification products and requirements.

1.03 REFERENCE STANDARDS

- A. AASHTO LTS - Standard Specifications for Structural Supports for Highway Signs, Luminaires and Traffic Signals 2013 (Revised 2019).
- B. IEEE C2 - National Electrical Safety Code 2017.
- C. NECA 1 - Standard for Good Workmanship in Electrical Construction 2015.
- D. NECA 303 - Standard for Installing and Maintaining Closed-Circuit Television (CCTV) Systems 2019.

1.04 ADMINISTRATIVE REQUIREMENTS

- A. Coordination:
 - 1. Coordinate the placement of cameras with structural members, ductwork, piping, equipment, luminaires, diffusers, fire suppression system components, and other potential conflicts installed under other sections or by others.
 - 2. Coordinate the work with other installers to provide power for cameras and equipment at required locations.
 - 3. Notify Architect of any conflicts with or deviations from Contract Documents. Obtain direction before proceeding with work.

1.05 SUBMITTALS

- A. See Section 013000 - Administrative Requirements, for submittal procedures.
- B. Product Data: Provide manufacturer's standard catalog pages and data sheets for each system component. Include ratings, configurations, standard wiring diagrams, dimensions, finishes, service condition requirements, and installed features.
 - 1. Camera Poles: Include information on maximum supported effective projected area (EPA) and weight for design wind speed.
- C. Camera Poles: Certify that products and associated supports comply with specified structural design criteria.

PART 2 PRODUCTS

2.01 ACCESSORIES

- A. Camera Mounting Supports: Where not factory installed, provide mounting supports necessary for installation.
 - 1. Products:
 - a. StrongPoles, LLC; HD Parapet Camera Mount: www.strongpoles.com/#sle.
 - b. StrongPoles, LLC; Parapet Mount: www.strongpoles.com/#sle.
 - c. StrongPoles, LLC; Surface Mount Pole: www.strongpoles.com/#sle.
- B. Camera Poles:
 - 1. Provide poles suitable for cameras, supports, and accessories to be installed.
 - 2. Structural Design Criteria:

- a. Comply with AASHTO LTS.
 - b. Wind Load: Include effective projected area (EPA) of cameras, supports, and accessories to be installed.
 - 1) Design Wind Speed: [] mph ([] kph), with gust factor of 1.3.
 - c. Dead Load: Include weight of proposed cameras, supports, and accessories.
 - d. [].
3. Pole Configuration: As indicated on drawings.
4. Pole Configuration:
- a. Material: Use steel or aluminum.
 - b. Shape: Use square or round, straight or tapered.
 - c. Mounting Height: [], unless otherwise indicated.
 - d. Mounting: Install on concrete foundation, height as indicated on the drawings, unless otherwise indicated.
5. Provide ground lug, accessible from handhole.
6. Provide the following:
- a. Top cap.
 - b. Handhole.
 - c. Anchor bolts with leveling nuts or leveling shims.
 - d. Anchor base cover.
 - e. Pole-top tenon, size as required for installed camera/bracket.
7. Products:
- a. StrongPoles, LLC; SteadyMax Camera Poles: www.strongpoles.com/#sle.
 - b. StrongPoles, LLC; 4 Inch Square Camera Poles: www.strongpoles.com/#sle.
 - c. StrongPoles, LLC; 5 Inch Square Direct-Burial Camera Poles: www.strongpoles.com/#sle.
- C. Provide components as indicated or as required for connection of video surveillance system to devices and other systems indicated.
- D. Provide cables as indicated or as required for connections between system components.
- E. Provide accessory racks/cabinets as indicated or as required for equipment mounting.

PART 3 EXECUTION

3.01 EXAMINATION

- A. Verify that field measurements are as indicated.
- B. Verify that ratings and configurations of system components are consistent with the indicated requirements.
- C. Verify that mounting surfaces are ready to receive system components.
- D. Verify that branch circuit wiring installation is completed, tested, and ready for connection to system where applicable.
- E. Verify that conditions are satisfactory for installation prior to starting work.

3.02 INSTALLATION

- A. Install video surveillance system in accordance with NECA 1 (general workmanship) and NECA 303.
- B. Install products in accordance with manufacturer's instructions.
- C. Provide required support and attachment in accordance with Section 260529.
- D. Pole-Mounted Cameras:
 - 1. Maintain the following minimum clearances:
 - a. Comply with IEEE C2.
 - b. Comply with utility company requirements.
 - 2. Foundation-Mounted Poles:
 - a. Provide cast-in-place concrete foundations for poles as indicated; see Section 033000.

- 1) Install anchor bolts plumb using template furnished by pole manufacturer.
- 2) Position conduits to enter pole shaft.
- b. Install foundations plumb.
- c. Install poles plumb, using shims as required to adjust to plumb.
- d. Tighten anchor bolt nuts to manufacturer's recommended torque.
- e. Install anchor base covers or anchor bolt covers as indicated.

3. Embedded Poles: Install poles plumb.

- E. Provide grounding and bonding in accordance with Section 260526.
- F. Install firestopping to preserve fire resistance rating of partitions and other elements, using materials and methods specified in Section 078400.
- G. Identify system wiring and components in accordance with Section 260553.

END OF SECTION